

PAT.NO.:				
PRODUITS DE SERVICE PUBLICS INNOVA INC. INNOVA PUBLIC UTILITY PRODUCTS INC.				
<small>© 9105-0732 QUEBEC INC. and under exclusive license to INNOVA PUBLIC UTILITY PRODUCTS INC., (hereafter « INNOVA »). All rights reserved. Protected under the Copyright Act of Canada and international treaties and agreements regarding copyrights. Violators are subject to prosecution and other legal recourses for infringement. Any reproduction, adaptation or other use or disclosure whatsoever, in totality or in part, and in any form or by any means whatsoever, strictly forbidden and requires the prior written approval of INNOVA. All data is the exclusive property of 9105-0732 QUEBEC INC. and under exclusive license to INNOVA and cannot be used nor disclosed in any way either without the prior written approval of INNOVA.</small>				
WEIGHT:	TITLE:			
65 Lb	140mm (5.5") Central Mount floor adapter			
29 Kg	(SS 304)			
COLOR:	Material:	SHEET(S):	PROJET:	Rev.
	SS 304	1 / 4	IN-2201	01

IN-2201 Base Installation Requirements (CSA,OSHA,ANSI)

Product number: **IN-2201**

Recommendations:

Concrete must be made of 0,2% gross area rebar reinforced 13.8 MPa (2000psi) or better. Minimum thickness of 203mm (8").

Moment capacity: 39,048 N-m (345,600 lbf-in)
 Vertical load: 22,241 N (5,000 lbf).
 Note: It is the responsibility of the field Engineer to assure installation compliance.

Hardware:

Anchor bolts: Chemical setting 3/4" x 6-5/8" effective holding length and made of 304/316 stainless steel
 Max pulling strength: 75,620 N (17,000 lbf).
 To be installed with 3/4" Stainless Steel Nuts, one (1) lockwasher and two (2) washers per bolt.

Full Thickness Installation

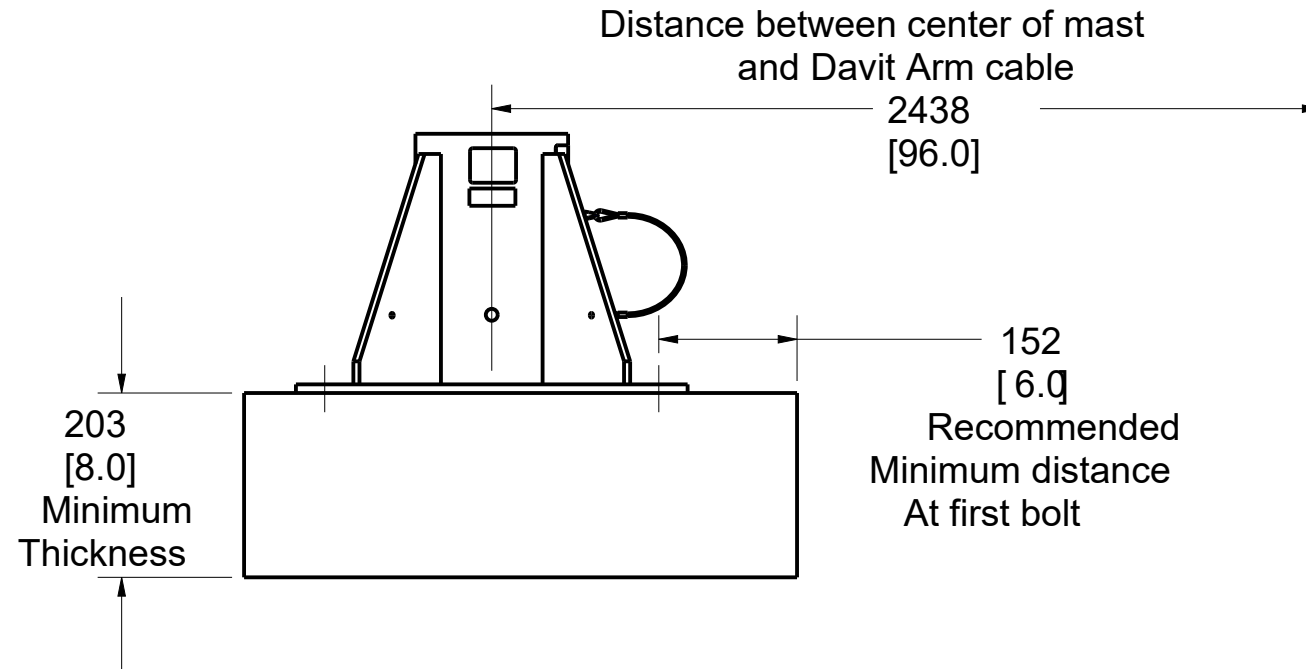

Sandwich Installation

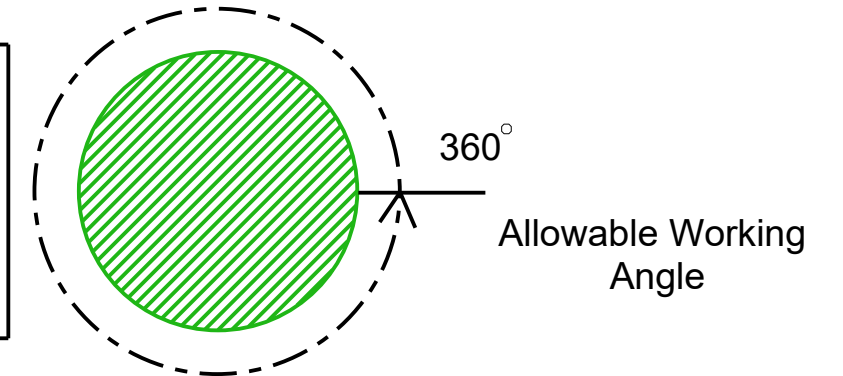
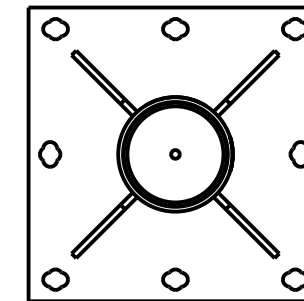
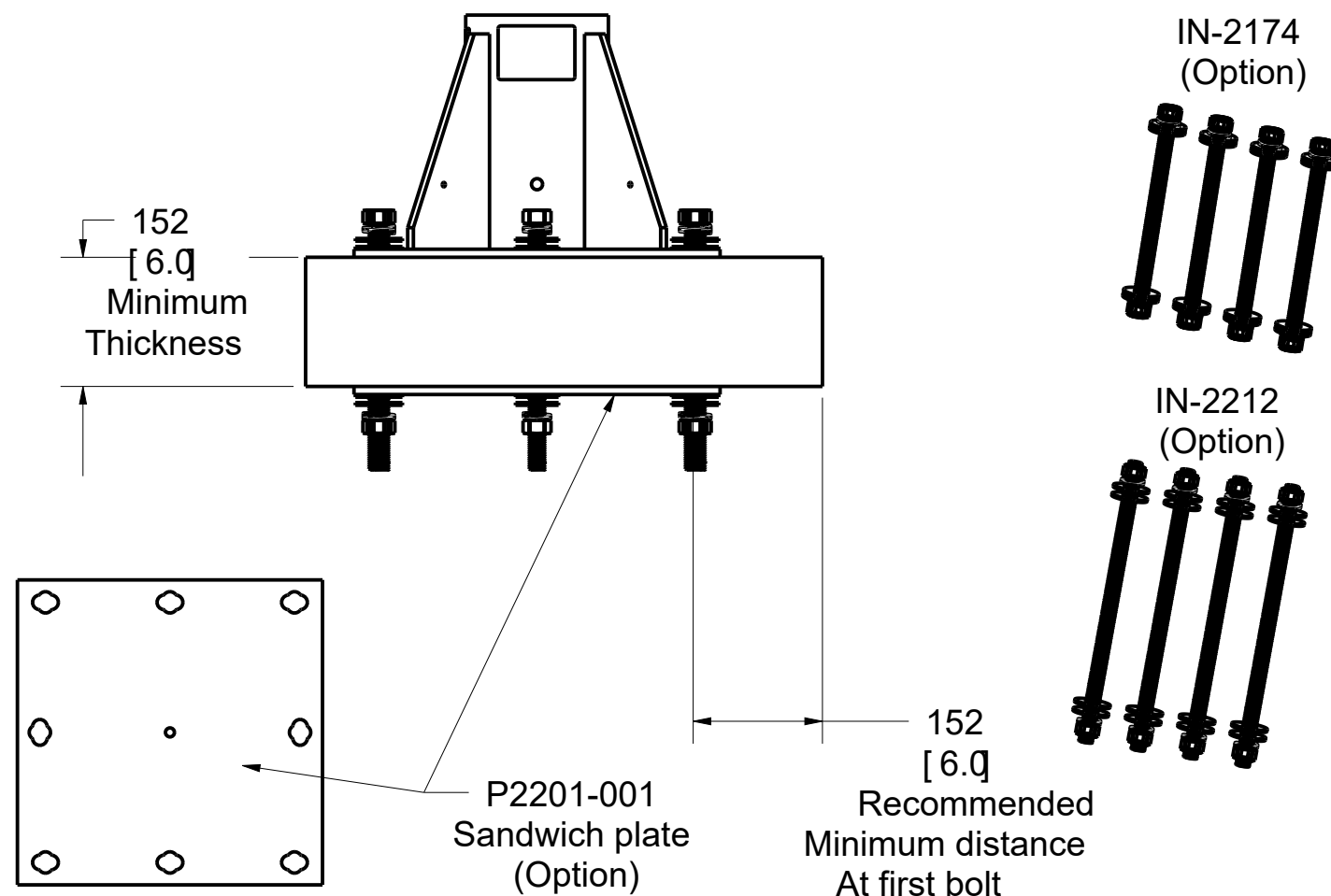

Recommendations:

Concrete must be made of 0,2% gross area rebar reinforced 13.8 MPa (2000psi) or better. Minimum thickness of 152mm (6").

Moment capacity: 39,048 N-m (345,600 lbf-in).
 Vertical load: 22,241 N (5,000 lbf).
 Note: It is the responsibility of the field Engineer to assure installation compliance.

Hardware:

Anchor Rods: 3/4" x 12" or 16" and made of 304/316 stainless steel. To be installed with 3/4" Stainless Steel Nuts, two (2) lockwashers and four (4) washers per bolt.

PAT.NO.:				
PRODUITS DE SERVICE PUBLICS INNOVA INC. INNOVA PUBLIC UTILITY PRODUCTS INC.				
<small>© 9105-0732 QUEBEC INC. and under exclusive license to INNOVA PUBLIC UTILITY PRODUCTS INC., (hereafter « INNOVA »). All rights reserved. Protected under the Copyright Act of Canada and international treaties and agreements regarding copyrights. Violators are subject to prosecution and other legal recourses for infringement. Any reproduction, adaptation or other use or disclosure whatsoever, in totality or in part, and in any form or by any means whatsoever, strictly forbidden and requires the prior written approval of INNOVA. All data is the exclusive property of 9105-0732 QUEBEC INC. and under exclusive license to INNOVA and cannot be used nor disclosed in any way either without the prior written approval of INNOVA.</small>				
WEIGHT:	TITLE:			
65 Lb	140mm (5.5") Central Mount floor adapter			
29 Kg	(SS 304)			
COLOR:	Material:	SHEET(S):	PROJET:	Rev.
	SS 304	2 / 4	IN-2201	01

SPECIFICATIONS

H This equipment is considered as part of a personal fall arrest system (PFAS) with a maximum working capacity of 164 Kg (360 lb).

It is only to be used in conjunction with a personal fall arrest system that limits the maximum arrest force (MAF).

G Maximum Working Moment: 3,905 N-m (34,560 lbf-in)
Maximum Moment: 39,048 N-m (345,600 lbf-in)

STANDARDS

Meets the following standards:

F OSHA Personal fall arrest system - 1910.66 App C
ANSI Safety requirements for personal fall arrest system, subsystems and components Z359.1 (R1999) / 2007
CAN/CSA Fall arresters, vertical lifelines, and rails Z259.2.1-98
EN 795: 2012 Type A
CEN/TS 16415: 2013 (3 Users)

E MATERIAL AND CONSTRUCTION

Plate, gussets and sleeve : 304 Stainless Steel
Sleeve bearing : PVC Pipe.
Welding Certification : CSA W59 & W47.1, AWS D1.6

D RESTRICTIONS

IMPORTANT :

C This adapter is to be used only with products approved by Innova Public Utility Products inc.

Anchor hardware must be installed by qualified and experienced personnel. The installer must follow the anchor hardware manufacturer's recommendations at all times.

B ****The positioning pins must always be in place when manoeuvring personnel. Otherwise, serious injuries may occur.**

Periodic inspections of hardware must be done. In the occurrence of a fall or the safety of the equipment is in doubt, equipment must be immediately removed from service and inspected by qualified personnel before reuse.

A **** This equipment must always be operated in a level position and on a flat surface over the entire base.**

Product number: IN-2201

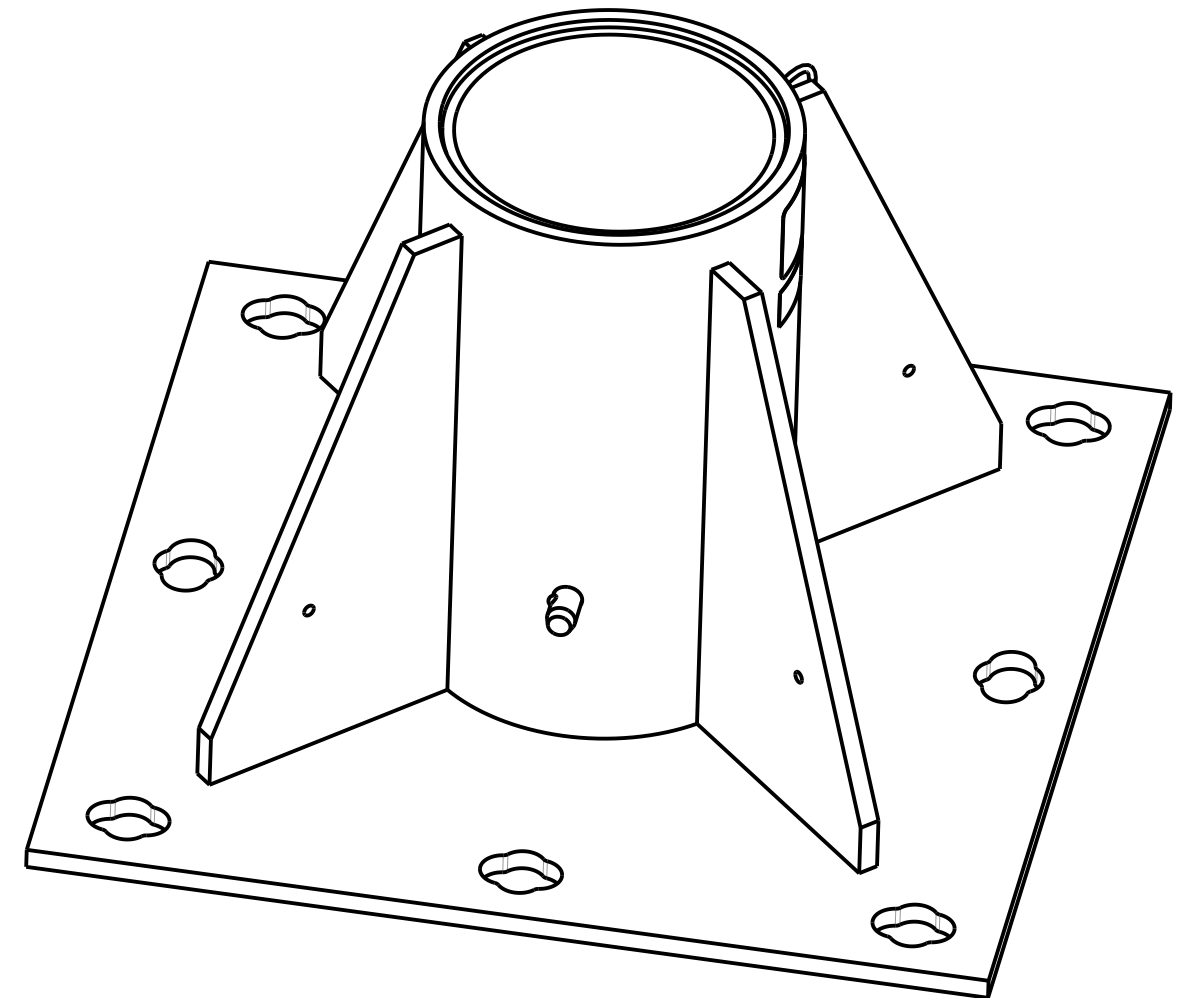

PAT.NO.:				
PRODUITS DE SERVICE PUBLICS INNOVA INC. INNOVA PUBLIC UTILITY PRODUCTS INC.				
<small>© 9105-0732 QUEBEC INC. and under exclusive license to INNOVA PUBLIC UTILITY PRODUCTS INC., (hereafter « INNOVA »). All rights reserved. Protected under the Copyright Act of Canada and international treaties and agreements regarding copyrights. Violators are subject to prosecution and other legal recourses for infringement. Any reproduction, adaptation or other use or disclosure whatsoever, in totality or in part, and in any form or by any means whatsoever, strictly forbidden and requires the prior written approval of INNOVA. All data is the exclusive property of 9105-0732 QUEBEC INC. and under exclusive license to INNOVA and cannot be used nor disclosed in any way either without the prior written approval of INNOVA.</small>				
WEIGHT:	TITLE:			
65 Lb	140mm (5.5") Central Mount floor adapter			
29 Kg	(SS 304)			
COLOR:	Material:	SHEET(S):	PROJET:	Rev.
	SS 304	3 / 4	IN-2201	01

8

7

6

5

4

3

2

1

Product number: IN-2201

H

G

F

E

D

C

B

A

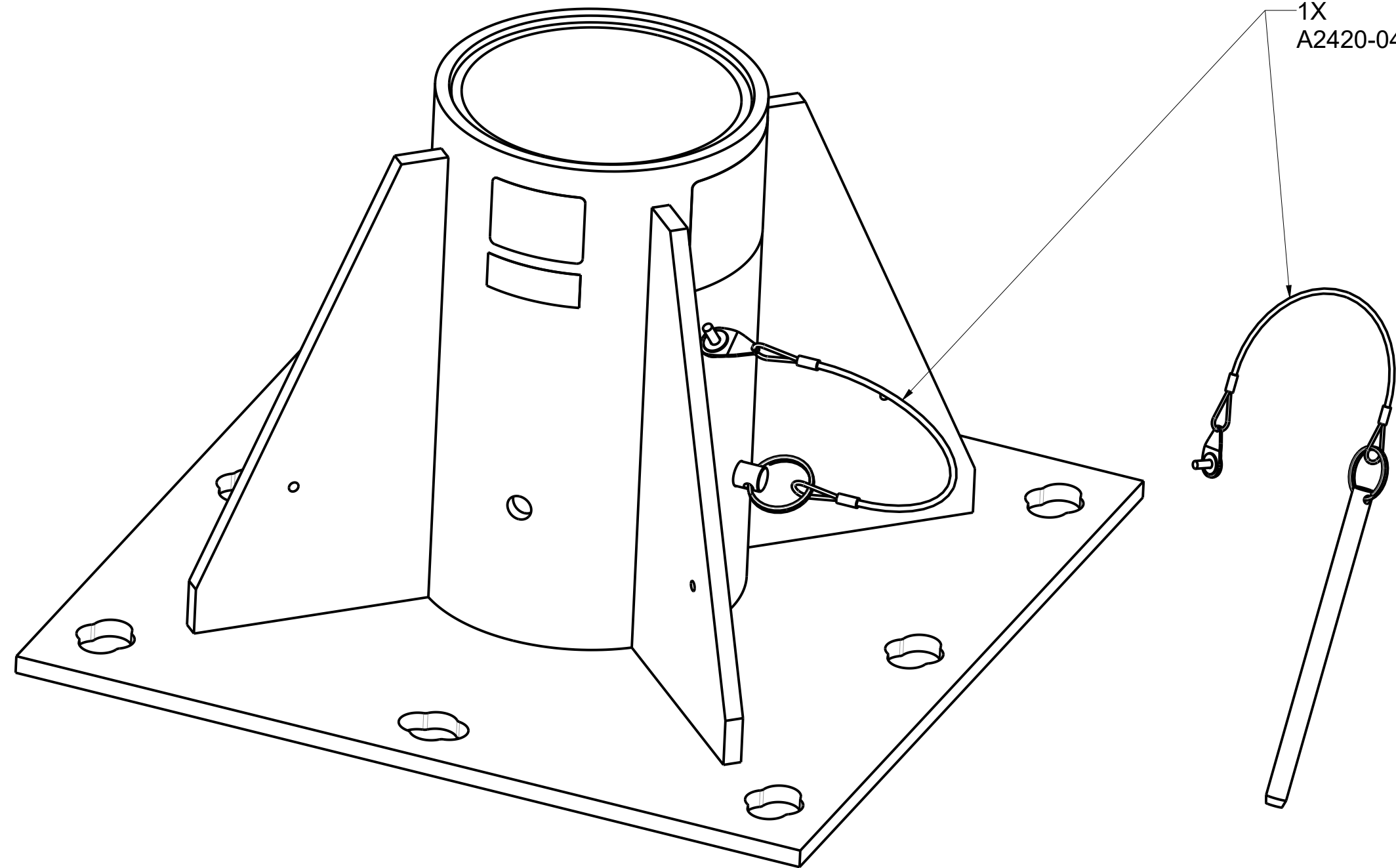

PAT.NO.:				
PRODUITS DE SERVICE PUBLICS INNOVA INC. INNOVA PUBLIC UTILITY PRODUCTS INC.				
© 9105-0732 QUEBEC INC. and under exclusive license to INNOVA PUBLIC UTILITY PRODUCTS INC., (hereafter « INNOVA »). All rights reserved. Protected under the Copyright Act of Canada and international treaties and agreements regarding copyrights. Violators are subject to prosecution and other legal recourses for infringement. Any reproduction, adaptation or other use or disclosure whatsoever, in totality or in part, and in any form or by any means whatsoever, strictly forbidden and requires the prior written approval of INNOVA. All data is the exclusive property of 9105-0732 QUEBEC INC. and under exclusive license to INNOVA and cannot be used nor disclosed in any way either without the prior written approval of INNOVA.				
WEIGHT:	TITLE:			
65 Lb	140mm (5.5") Central Mount floor adapter			
29 Kg	(SS 304)			
COLOR:	Material:	SHEET(S):	PROJET:	Rev.
	SS 304	4 / 4	IN-2201	01

8

7

6

5

4

3

2

1