

Product number: IN-2101

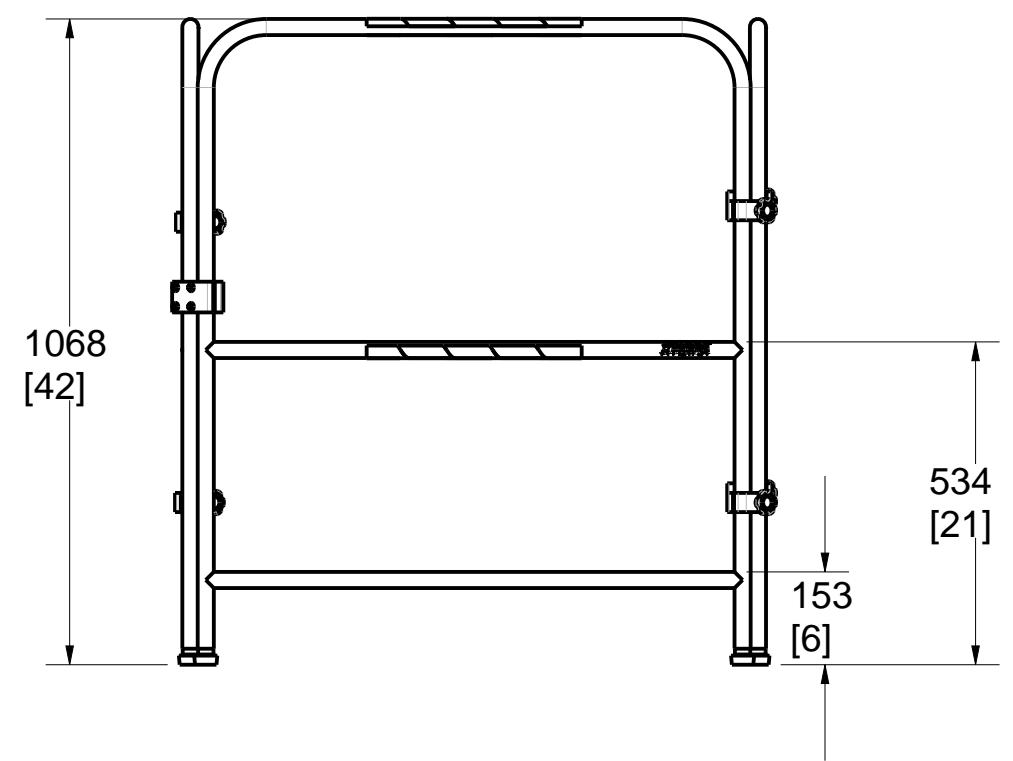
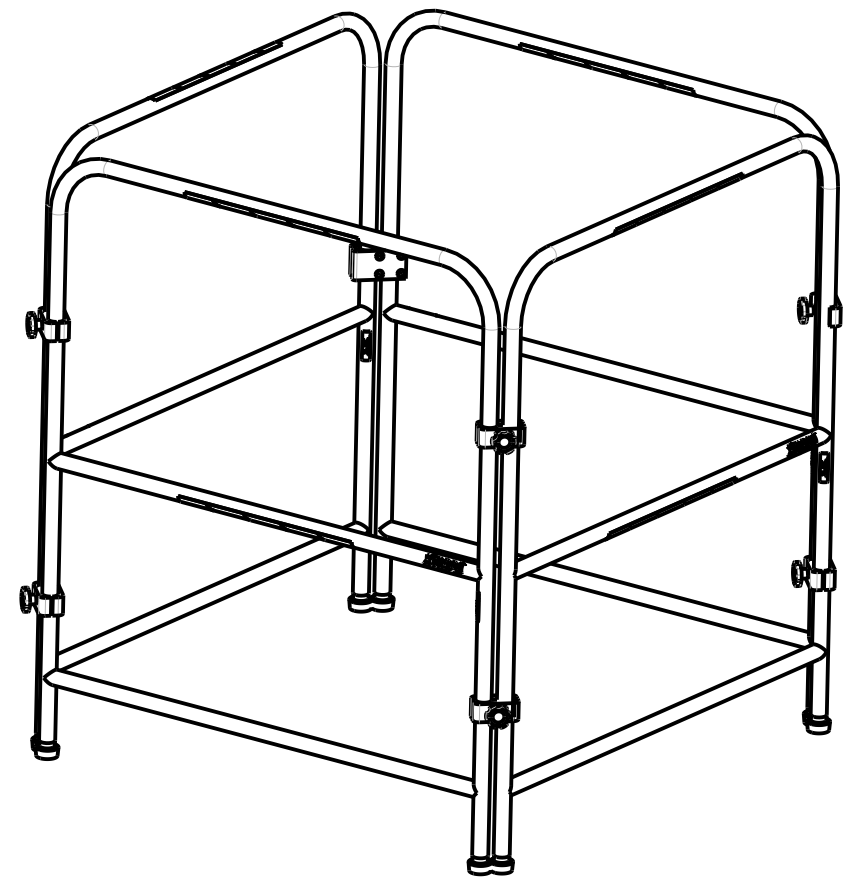
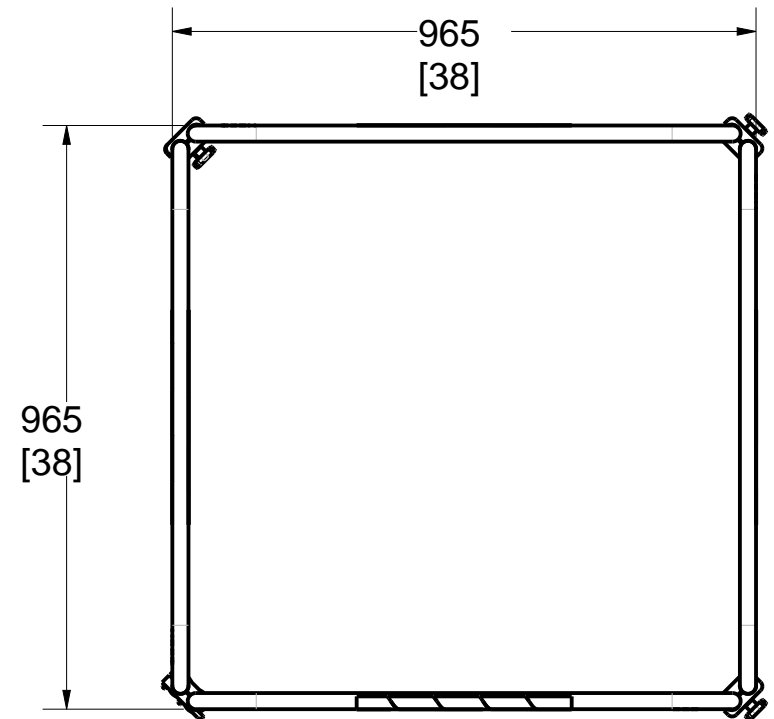

PAT. NO.: ©16/04/2010 ©

PRODUITS DE SERVICE PUBLICS INNOVA INC.
INNOVA PUBLIC UTILITY PRODUCTS INC.

© 9105-0732 QUEBEC INC. and under exclusive license to INNOVA PUBLIC UTILITY PRODUCTS INC., (hereafter « INNOVA »). All rights reserved. Protected under the Copyright Act of Canada and international treaties and agreements regarding copyrights. Violators are subject to prosecution and other legal recourses for infringement. Any reproduction, adaptation or other use or disclosure whatsoever, in totality or in part, and in any form or by any means whatsoever, strictly forbidden and requires the prior written approval of INNOVA. All data is the exclusive property of 9105-0732 QUEBEC INC. and under exclusive license to INNOVA and cannot be used nor disclosed in any way either without the prior written approval of INNOVA.

WEIGHT:	TITLE:
28 Lb 13 Kg	Multifunctional Barricade

COLOR: Safety Yellow	MATERIAL: Aluminum	SHEET(S): 1 / 4	PROJECT: IN-2101
-------------------------	-----------------------	--------------------	---------------------

Sections Available

Possible Sample configuration

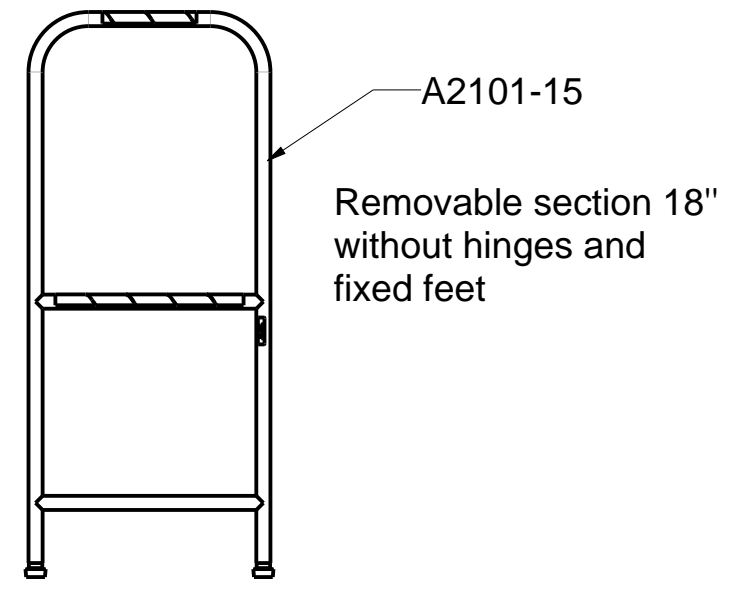
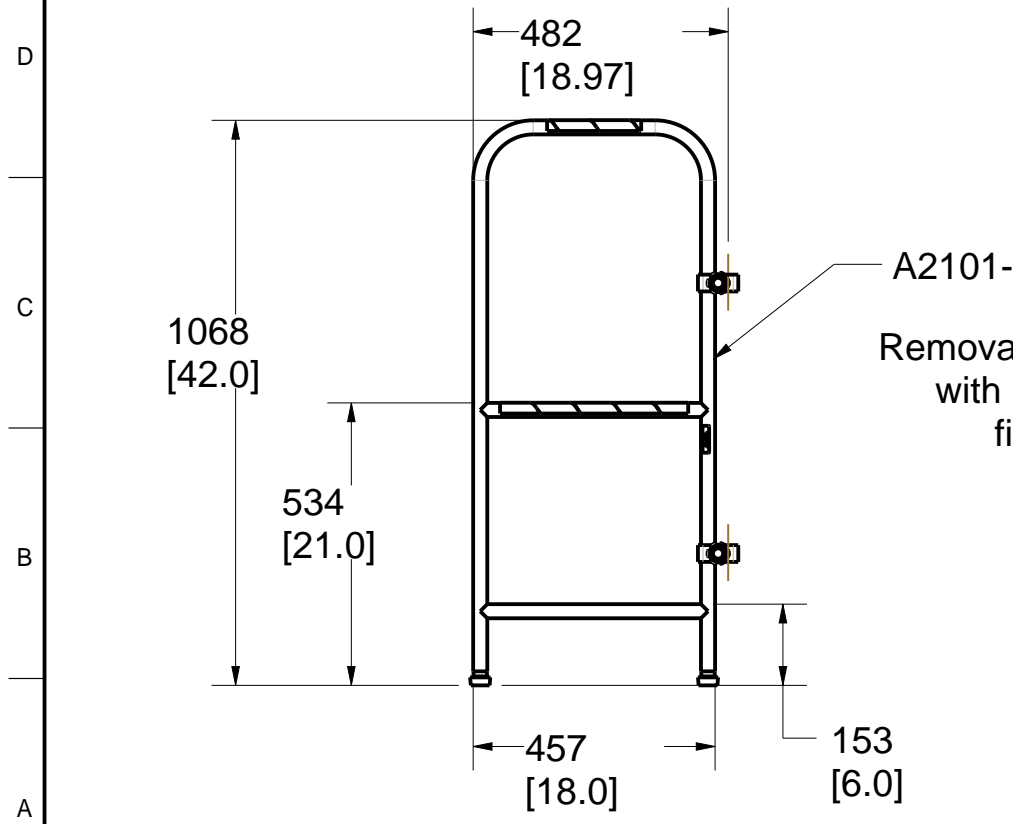
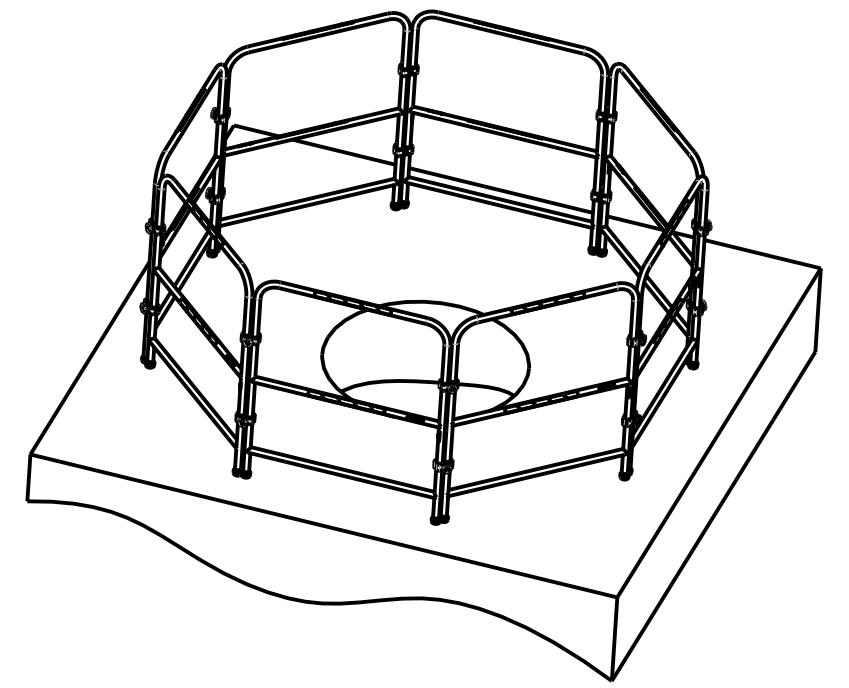
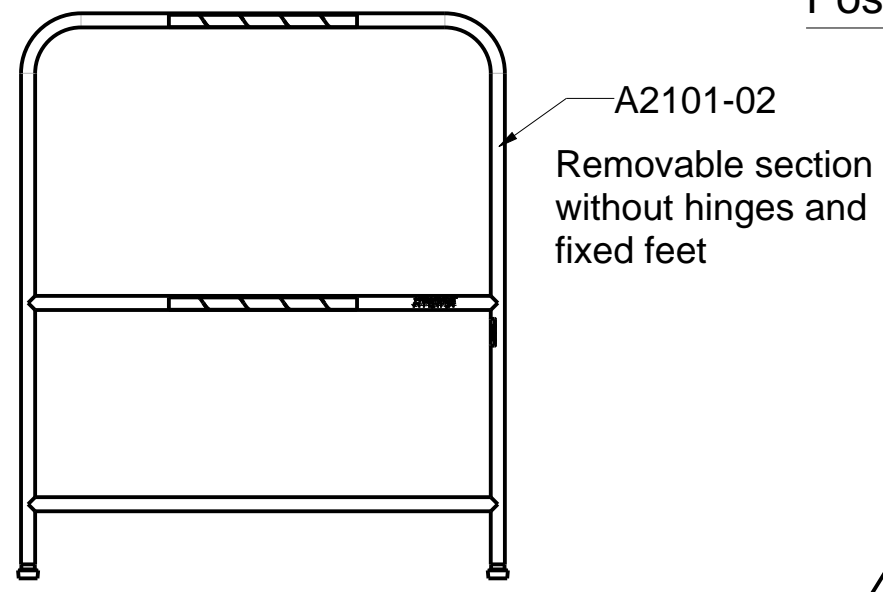
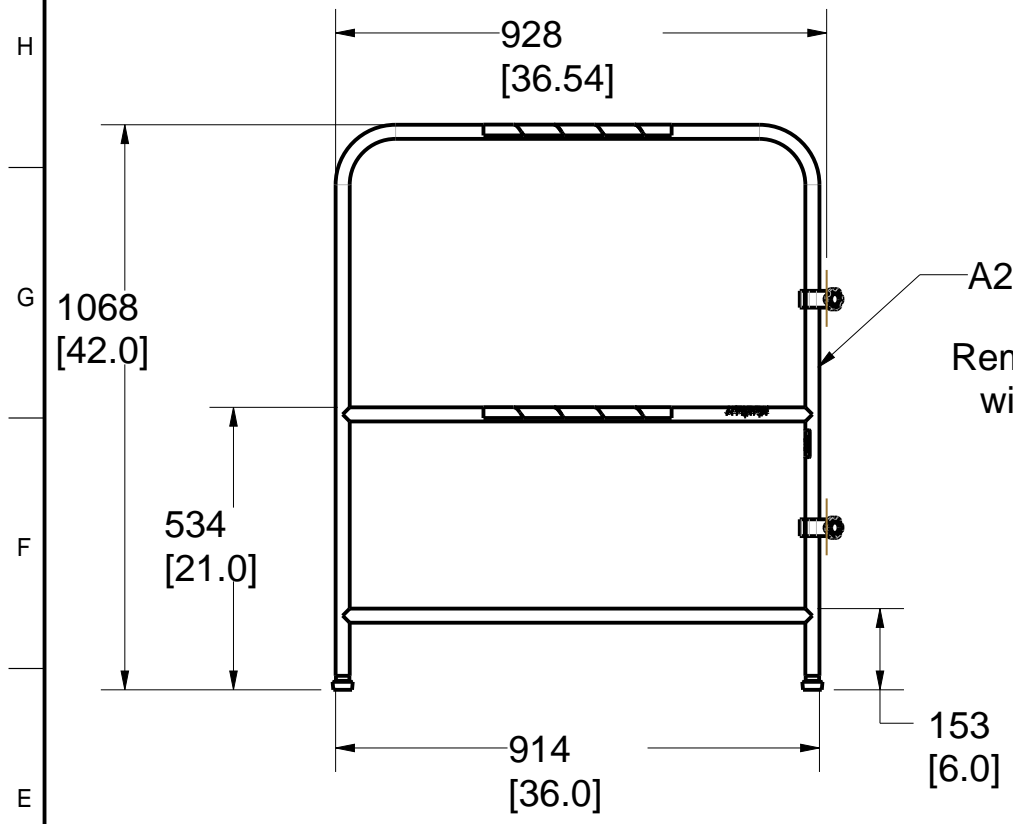

PAT. NO.:		©16/04/2010	©
PRODUITS DE SERVICE PUBLICS INNOVA INC. INNOVA PUBLIC UTILITY PRODUCTS INC.			
© 9105-0732 QUEBEC INC. and under exclusive license to INNOVA PUBLIC UTILITY PRODUCTS INC., (hereafter « INNOVA »). All rights reserved. Protected under the Copyright Act of Canada and international treaties and agreements regarding copyrights. Violators are subject to prosecution and other legal recourses for infringement. Any reproduction, adaptation or other use or disclosure whatsoever, in totality or in part, and in any form or by any means whatsoever, strictly forbidden and requires the prior written approval of INNOVA. All data is the exclusive property of 9105-0732 QUEBEC INC. and under exclusive license to INNOVA and cannot be used nor disclosed in any way either without the prior written approval of INNOVA.			
WEIGHT:	TITLE:		
28 Lb	Multifunctional Barricade with removable section and ajustable feet		
13 Kg			
COLOR:	MATERIAL:	SHEET(S):	PROJECT:
Safety Yellow	Aluminum	2 / 4	IN-2101

SPECIFICATIONS

Portable Barricade for delimiting a working or a hazard area.

Vertical capacity at any point : 450N (101 lbf)

STANDARDS

N/A

MATERIAL AND CONSTRUCTION

Structural tubes : Aluminum 6061-T6
 Feet : Steel, black acetal and Rubber
 Hardware : Zinc plated steel and stainless steel
 Hinges and door lock : Black polyurethane
 Finish : Yellow security powder paint with metal protection.
 Welding certification: CSA W47.2M

RESTRICTIONS

This equipment must be used on a solid and stable surface.
 This product is not intended to receive or support a man rated davit arm.
 This product is not designed to control a crowd or resist to a horizontal force greater than its own weight.

Product number: IN-2101

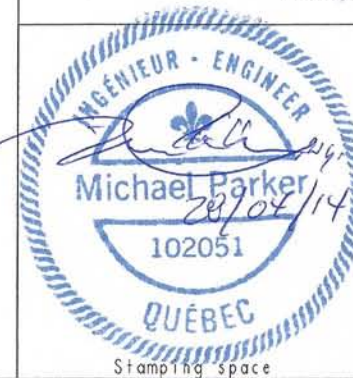
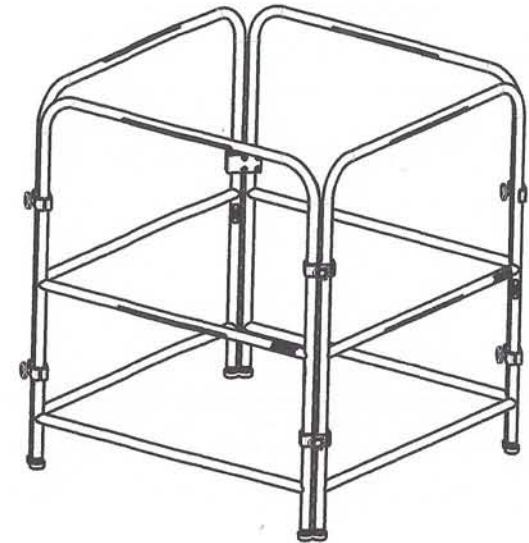

PAT. NO. :		016/04/2010 ©	
© 9100-0732 QUÉBEC INC. and under exclusive license to INNOVA PUBLIC UTILITY PRODUCTS INC., thereafter a INNOVA s7. All rights reserved. Protected under the Copyright Act of Canada and International treaties and agreements regarding copyrights. Violators are subject to prosecution and other legal remedies for infringement. Any reproduction, adaptation or other use or disclosure whatsoever, in totality or in part, and in any form or by any means whatsoever, strictly forbidden and requires the prior written approval of INNOVA. All data is the exclusive property of 9100-0732 QUÉBEC INC. and under exclusive license to INNOVA and cannot be used nor disclosed in any way without the prior written approval of INNOVA.			
WEIGHT:		TITLE:	
28 Lb		Multifunctional Barricade	
13 Kg			
COLOR:	MATERIAL:	SHEET(S):	PROJECT:
Safety Yellow	Aluminum	3 / 4	IN-2101

8

7

6

5

4

3

2

1

Product number: **IN-2101**

2	4	S2001-003	04	XTIRPA Label
1	8	S2108-008		14" Reflective label
IDX	QTE	COMPONENT	REV	DESCRIPTION

H
G
F
E
D
C
B
A

H
G
F
E
D
C
B
A

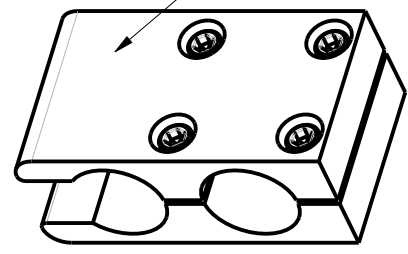
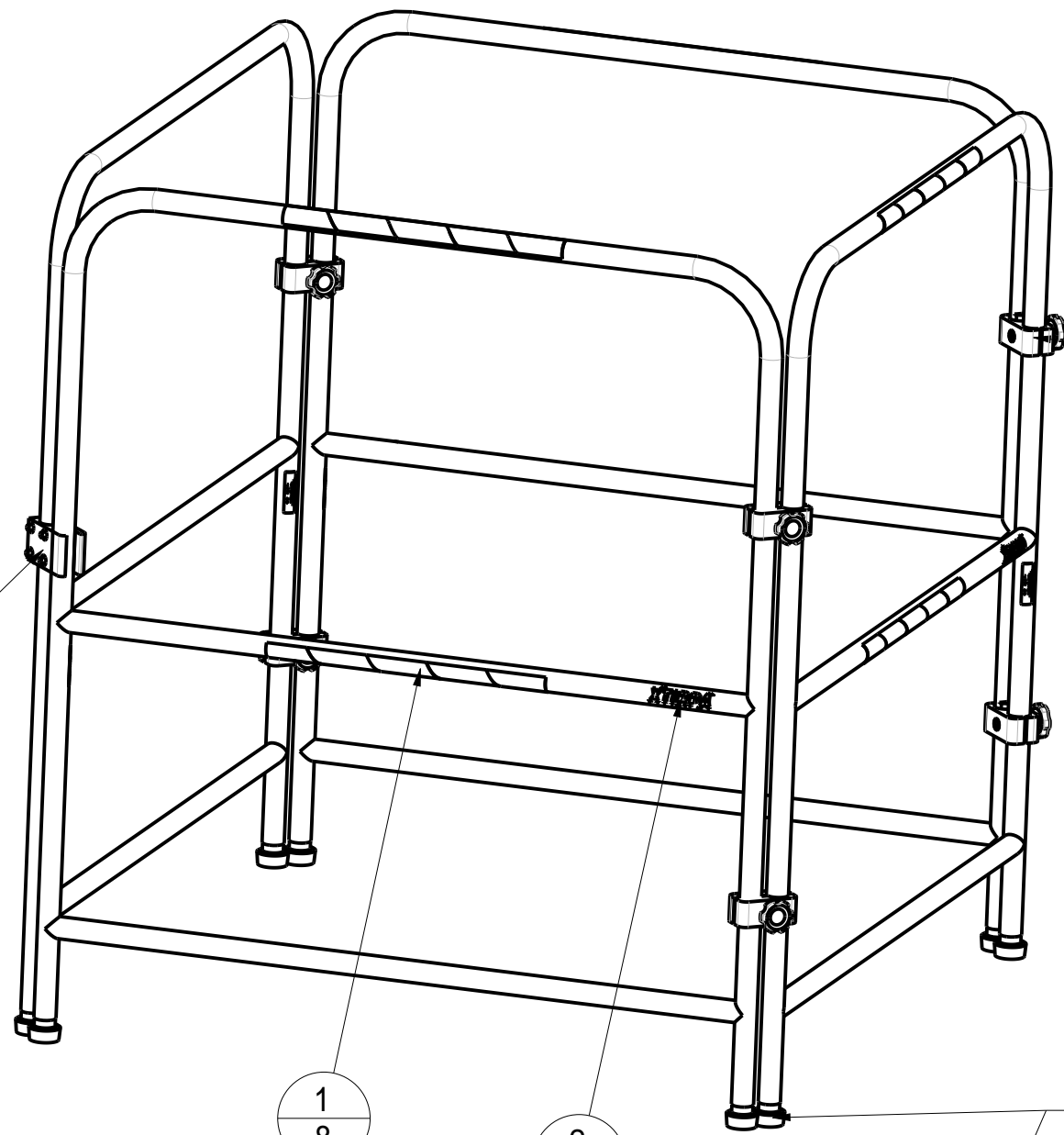

A2101-05
1X

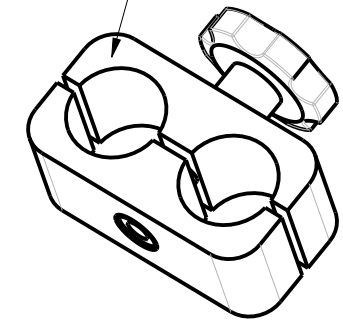

A2101-04
6X

1
8

2
4

A2101-11
8X

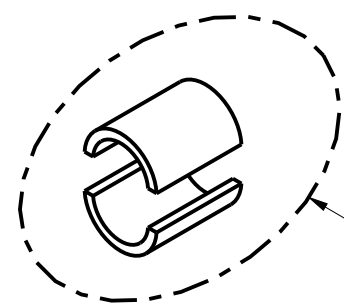
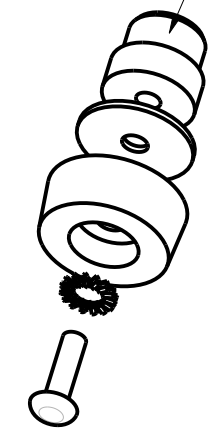

A2101-18 (1x)
Rubber spacer
for 1/2-ced 40 (0.84") pipe
(OPTION)

PAT. NO.:		©16/04/2010	©
PRODUITS DE SERVICE PUBLICS INNOVA INC. INNOVA PUBLIC UTILITY PRODUCTS INC.			
© 9105-0732 QUEBEC INC. and under exclusive license to INNOVA PUBLIC UTILITY PRODUCTS INC., (hereafter « INNOVA »). All rights reserved. Protected under the Copyright Act of Canada and international treaties and agreements regarding copyrights. Violators are subject to prosecution and other legal recourses for infringement. Any reproduction, adaptation or other use or disclosure whatsoever, in totality or in part, and in any form or by any means whatsoever, strictly forbidden and requires the prior written approval of INNOVA. All data is the exclusive property of 9105-0732 QUEBEC INC. and under exclusive license to INNOVA and cannot be used nor disclosed in any way either without the prior written approval of INNOVA.			
WEIGHT:	TITLE:		
28 Lb	Multifunctional Barricade with removable section and ajustable feet		
13 Kg			
COLOR:	MATERIAL:	SHEET(S):	PROJECT:
Safety Yellow	Aluminum	4 / 4	IN-2101

8

7

6

5

4

3

2

1